

Operator's Manual

CRAFTSMAN®

ROUTER

Double Insulated

Model No.
315.175341

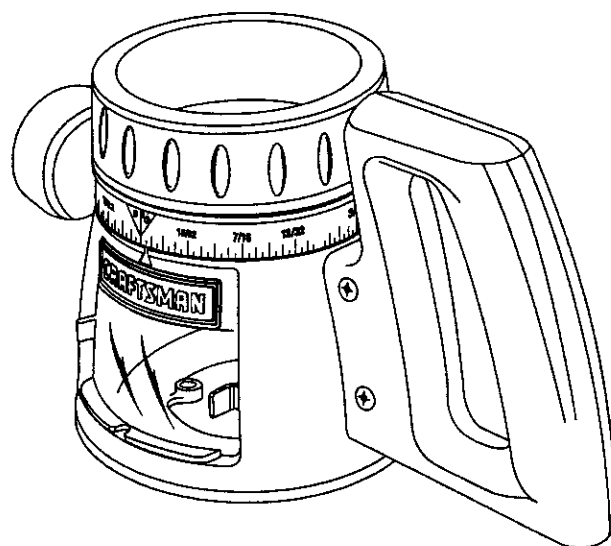
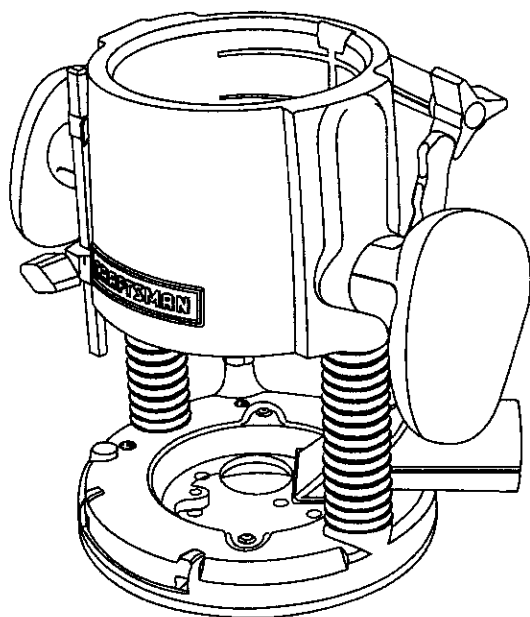
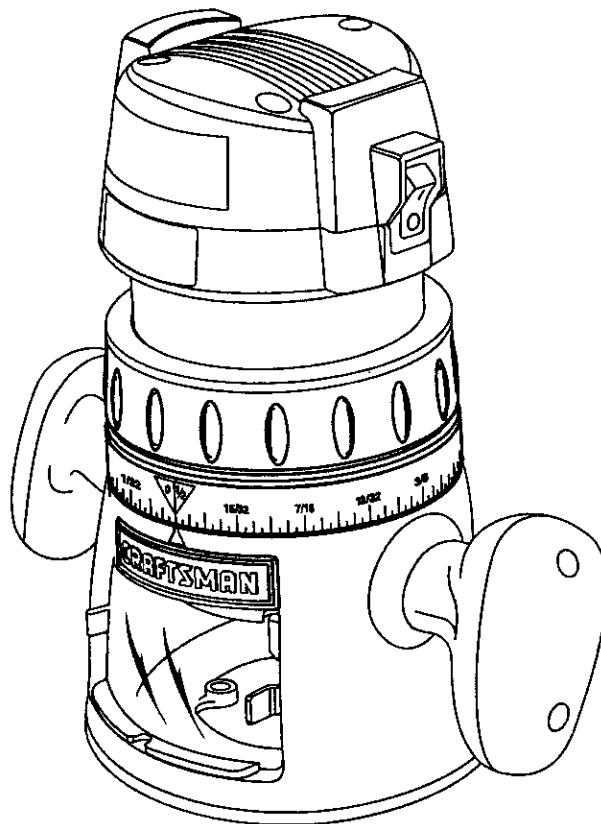

Save this manual for future reference

▲ CAUTION: Read and follow all safety rules and operating instructions before first use of this product.

Customer Help Line: 1-800-932-3188

Sears, Roebuck and Co., 3333 Beverly Rd., Hoffman Estates, IL 60179 USA
Visit the Craftsman Web page: www.sears.com/craftsman



TABLE OF CONTENTS

■ Warranty	2
■ General Safety Rules	3
■ Specific Safety Rules	4
■ Symbols	5-6
■ Electrical	7
■ Features	8
■ Unpacking	9
■ Operation	10-18
■ Maintenance	19
■ Accessories	20
■ Exploded View and Repair Parts List	22-23
■ Customer Service Information	24

WARRANTY

FULL ONE YEAR WARRANTY ON CRAFTSMAN ROUTER

If this **CRAFTSMAN** tool fails to give complete satisfaction within one year from the date of purchase, return it to the nearest Sears store in the United States, and Sears will repair it, free of charge.

If this **CRAFTSMAN** tool is used for commercial or rental purposes, this warranty applies for only 90 days from the date of purchase.

This warranty gives you specific legal rights, and you may also have other rights which vary from state to state.

Sears, Roebuck and Co., Dept. 817 WA, Hoffman Estates, IL 60179

GENERAL SAFETY RULES

- ⚠ WARNING:** Read and understand all instructions. Failure to follow all instructions listed below, may result in electric shock, fire and/or serious personal injury.

SAVE THESE INSTRUCTIONS

WORK AREA

- **Keep your work area clean and well lit.** Cluttered benches and dark areas invite accidents.
- **Do not operate power tools in explosive atmospheres, such as in the presence of flammable liquids, gases, or dust.** Power tools create sparks which may ignite the dust or fumes.
- **Keep bystanders, children, and visitors away while operating a power tool.** Distractions can cause you to lose control.

ELECTRICAL SAFETY

- **Double insulated tools are equipped with a polarized plug (one blade is wider than the other). This plug will fit in a polarized outlet only one way. If the plug does not fit fully in the outlet, reverse the plug. If it still does not fit, contact a qualified electrician to install a polarized outlet. Do not change the plug in any way.** Double insulation eliminates the need for the three-wire grounded power cord and grounded power supply system.
- **Avoid body contact with grounded surfaces such as pipes, radiators, ranges, and refrigerators.** There is an increased risk of electric shock if your body is grounded.
- **Don't expose power tools to rain or wet conditions.** Water entering a power tool will increase the risk of electric shock.
- **Do not abuse the cord. Never use the cord to carry the tools or pull the plug from an outlet. Keep cord away from heat, oil, sharp edges, or moving parts. Replace damaged cords immediately.** Damaged cords increase the risk of electric shock.
- **When operating a power tool outside, use an outdoor extension cord marked "W-A" or "W".** These cords are rated for outdoor use and reduce the risk of electric shock.

PERSONAL SAFETY

- **Stay alert, watch what you are doing and use common sense when operating a power tool. Do not use tool while tired or under the influence of drugs, alcohol, or medication.** A moment of inattention while operating power tools may result in serious personal injury.
- **Dress properly. Do not wear loose clothing or jewelry. Contain long hair. Keep your hair, clothing, and gloves away from moving parts.** Loose clothes, jewelry, or long hair can be caught in moving parts.
- **Avoid accidental starting. Be sure switch is off before plugging in.** Carrying tools with your finger

on the switch or plugging in tools that have the switch on invites accidents.

- **Remove adjusting keys or wrenches before turning the tool on.** A wrench or a key that is left attached to a rotating part of the tool may result in personal injury.
- **Do not overreach. Keep proper footing and balance at all times.** Proper footing and balance enables better control of the tool in unexpected situations.
- **Use safety equipment. Always wear eye protection.** Dust mask, nonskid safety shoes, hard hat, or hearing protection must be used for appropriate conditions.
- **Do not wear loose clothing or jewelry. Contain long hair.** Loose clothes, jewelry, or long hair can be drawn into air vents.
- **Do not use on a ladder or unstable support.** Stable footing on a solid surface enables better control of the tool in unexpected situations.

TOOL USE AND CARE

- **Use clamps or other practical way to secure and support the workpiece to a stable platform.** Holding the work by hand or against your body is unstable and may lead to loss of control.
- **Do not force tool. Use the correct tool for your application.** The correct tool will do the job better and safer at the rate for which it is designed.
- **Do not use tool if switch does not turn it on or off.** Any tool that cannot be controlled with the switch is dangerous and must be repaired.
- **Disconnect the plug from power source before making any adjustments, changing accessories, or storing the tool.** Such preventive safety measures reduce the risk of starting the tool accidentally.
- **Store idle tools out of the reach of children and other untrained persons.** Tools are dangerous in the hands of untrained users.
- **Maintain tools with care. Keep cutting tools sharp and clean.** Properly maintained tools with sharp cutting edges are less likely to bind and are easier to control.
- **Check for misalignment or binding of moving parts, breakage of parts, and any other condition that may affect the tool's operation. If damaged, have the tool serviced before using.** Many accidents are caused by poorly maintained tools.
- **Use only accessories that are recommended by the manufacturer for your model.** Accessories that may be suitable for one tool, may become hazardous when used on another tool.
- **Keep the tool and its handle dry, clean and free from oil and grease.** Always use a clean cloth when cleaning. Never use brake fluids, gasoline, petroleum-based products, or any strong solvents to clean your tool. Following this rule will reduce the risk of loss of control and deterioration of the enclosure plastic.

GENERAL SAFETY RULES

SERVICE

- **Tool service must be performed only by qualified repair personnel.** Service or maintenance performed by unqualified personnel could result in a risk of injury.

- **When servicing a tool, use only identical replacement parts.** Follow instructions in the Maintenance section of this manual. Use of unauthorized parts or failure to follow Maintenance Instructions may create a risk of electric shock or injury.

SPECIFIC SAFETY RULES

- **Hold tool by insulated gripping surfaces when performing an operation where the cutting tool may contact hidden wiring or its cord.** Contact with a "live" wire will make exposed metal parts of the tool "live" and shock the operator.

ADDITIONAL SAFETY RULES

- **Know your power tool.** Read operator's manual carefully. Learn its applications and limitations, as well as the specific potential hazards related to this tool. Following this rule will reduce the risk of electric shock, fire, or serious injury.
- **Always wear safety glasses.** Everyday eyeglasses have only impact-resistant lenses; they are NOT safety glasses. Following this rule will reduce the risk of serious personal injury.
- **Protect your lungs.** Wear a face or dust mask if the operation is dusty. Following this rule will reduce the risk of serious personal injury.
- **Protect your hearing.** Wear hearing protection during extended periods of operation. Following this rule will reduce the risk of serious personal injury.
- **Inspect tool cords periodically and, if damaged, have repaired at your nearest Authorized Service Center.** Constantly stay aware of cord location. Following this rule will reduce the risk of electric shock or fire.
- **Never attempt to use the router motor without first installing it in the fixed base (Model No. 315.175310), D-handle base (Model No. 315.175300), or plunge base (Model No. 315.175320).**
- **Check damaged parts.** Before further use of the tool, a guard or other part that is damaged should be carefully checked to determine that it will operate properly and perform its intended

function. Check for alignment of moving parts, binding of moving parts, breakage of parts, mounting, and any other conditions that may affect its operation. A guard or other part that is damaged should be properly repaired or replaced by an authorized service center. Following this rule will reduce the risk of shock, fire, or serious injury.

- **Do not abuse cord.** Never carry the tool by the cord or yank it to disconnect it from the receptacle. Keep cord away from heat, oil, and sharp edges. Following this rule will reduce the risk of electric shock or fire.
- **Make sure your extension cord is in good condition.** When using an extension cord, be sure to use one heavy enough to carry the current your product will draw. A wire gage size (A.W.G.) of at least 14 is recommended for an extension cord 50 feet or less in length. A cord exceeding 100 feet is not recommended. If in doubt, use the next heavier gage. The smaller the gage number, the heavier the cord. An undersized cord will cause a drop in line voltage resulting in loss of power and overheating.
- **Inspect for and remove all nails from lumber before using this tool.** Following this rule will reduce the risk of serious personal injury.
- **Drugs, alcohol, medication.** Do not operate tool while under the influence of drugs, alcohol, or any medication. Following this rule will reduce the risk of electric shock, fire, or serious personal injury.
- **Save these instructions.** Refer to them frequently and use them to instruct others who may use this tool. If you loan someone this tool, loan them these instructions also.









⚠ WARNING: Some dust created by power sanding, sawing, grinding, drilling, and other construction activities contains chemicals known to cause cancer, birth defects or other reproductive harm. Some examples of these chemicals are:

- lead from lead-based paints,
- crystalline silica from bricks and cement and other masonry products, and
- arsenic and chromium from chemically-treated lumber.

Your risk from these exposures varies, depending on how often you do this type of work. To reduce your exposure to these chemicals: work in a well ventilated area, and work with approved safety equipment, such as those dust masks that are specially designed to filter out microscopic particles.



SYMBOLS

Some of the following symbols may be used on this tool. Please study them and learn their meaning. Proper interpretation of these symbols will allow you to operate the tool better and safer.

SYMBOL	NAME	DESIGNATION/EXPLANATION
V	Volts	Voltage
A	Amperes	Current
Hz	Hertz	Frequency (cycles per second)
W	Watt	Power
min	Minutes	Time
~	Alternating Current	Type of current
==	Direct Current	Type or a characteristic of current
n_0	No Load Speed	Rotational speed, at no load
	Class II Construction	Double-insulated construction
.../min	Per Minute	Revolutions, strokes, surface speed, orbits etc., per minute
	Wet Conditions Alert	Do not expose to rain or use in damp locations.
	Read The Operator's Manual	To reduce the risk of injury, the user must read and understand the operator's manual before using this product.
	Eye Protection	Always wear safety goggles or safety glasses with side shields and a full face shield when operating this product.
	Safety Alert	Precautions that involve your safety.
	No Hands Symbol	Failure to keep your hands away from the blade will result in serious personal injury.
	No Hands Symbol	Failure to keep your hands away from the blade will result in serious personal injury.
	No Hands Symbol	Failure to keep your hands away from the blade will result in serious personal injury.
	No Hands Symbol	Failure to keep your hands away from the blade will result in serious personal injury.

SYMBOLS

The following signal words and meanings are intended to explain the levels of risk associated with this product.

SYMBOL	MEANING
	DANGER: Indicates an imminently hazardous situation, which, if not avoided, will result in death or serious injury.
	WARNING: Indicates a potentially hazardous situation, which, if not avoided, could result in death or serious injury.
	CAUTION: Indicates a potentially hazardous situation, which, if not avoided, may result in minor or moderate injury.
	(Without Safety Alert Symbol) Indicates a situation that may result in property damage.

SERVICE

Servicing requires extreme care and knowledge and should be performed only by a qualified service technician. For service we suggest you return the product to your nearest **AUTHORIZED SERVICE CENTER** for repair. When servicing, use only identical replacement parts.

 **WARNING:** Observe all normal safety precautions related to avoiding electrical shock.

 **WARNING:** To avoid serious personal injury, do not attempt to use this product until you read thoroughly and understand completely the operator's manual. Save this operator's manual and review frequently for continuing safe operation and instructing others who may use this product.

WARNING:



The operation of any tool can result in foreign objects being thrown into your eyes, which can result in severe eye damage. Before beginning operation, always wear safety goggles or safety glasses with side shields and a full face shield when needed. We recommend Wide Vision Safety Mask for use over eyeglasses or standard safety glasses with side shields. Always wear eye protection which is marked to comply with ANSI Z87.1.

SAVE THESE INSTRUCTIONS

ELECTRICAL

DOUBLE INSULATION

Double insulation is a concept in safety in electric power tools, which eliminates the need for the usual three-wire grounded power cord. All exposed metal parts are isolated from the internal metal motor components with protecting insulation. Double insulated tools do not need to be grounded.

⚠ WARNING: The double insulated system is intended to protect the user from shock resulting from a break in the tool's internal wiring. Observe all normal safety precautions to avoid electrical shock.

Important: Servicing of a tool with double insulation requires extreme care and knowledge of the system and should be performed only by a qualified service technician. For service, we suggest you return the tool to your nearest authorized service center for repair. When servicing, use only identical Craftsman replacement parts.

ELECTRICAL CONNECTION

The router has a precision built electric motor. It should be connected to a **power supply that is 120 volts, 60 Hz, AC only (normal household current)**. Do not operate this tool on direct current (DC). A substantial voltage drop will cause a loss of power and the motor will overheat. If your tool does not operate when plugged into an outlet, double-check the power supply.

EXTENSION CORDS

When using a power tool at a considerable distance from a power source, be sure to use an extension cord that has the capacity to handle the current the tool will draw. An undersized cord will cause a drop in line voltage, resulting in overheating and loss of power. Use the chart to determine the minimum wire size required in an extension cord. Only round jacketed cords listed by Underwriter's Laboratories (UL) should be used.

When working outdoors with a tool, use an extension cord that is designed for outside use. This type of cord is designated with "WA" on the cord's jacket.

Before using any extension cord, inspect it for loose or exposed wires and cut or worn insulation.

**Ampere rating (on tool faceplate)						
	0-2.0	2.1-3.4	3.5-5.0	5.1-7.0	7.1-12.0	12.1-16.0
Cord Length	Wire Size (A.W.G.)					
25'	16	16	16	16	14	14
50'	16	16	16	14	14	12
100'	16	16	14	12	10	—

***Used on 12 gauge - 20 amp circuit.*

⚠ CAUTION: Keep the extension cords clear of the working area. Position the cord so that it will not get caught on lumber, tools, or other obstructions while you are working with a power tool. Failure to do so can result in serious personal injury.

⚠ WARNING: Check extension cords before each use. If damaged replace immediately. Never use tool with a damaged cord since touching the damaged area could cause electrical shock resulting in serious injury.

FEATURES

PRODUCT SPECIFICATIONS

Depth of Cut (Fixed Base & D-handle Base)	1-1/2 in.
Depth of Plunge (Plunge Base)	2 in.
Collet	1/4 in.
Horsepower	2
Rating	120 Volts, 60 Hz, AC only, 9.5 Amperes
No Load Speed	25,000/min
Power Cord	10 ft.
Net Weight	5 lbs. 6 oz.

KNOW YOUR ROUTER

Before attempting to use this product, familiarize yourself with all operating features and safety rules.

Your new router motor is equipped with the following features. See Figure 1.

SWITCH

The router has a conveniently located toggle switch.

SPINDLE LOCK

The spindle lock secures the spindle while you make adjustments and acts as a retainer to keep the router body from coming out of the base.

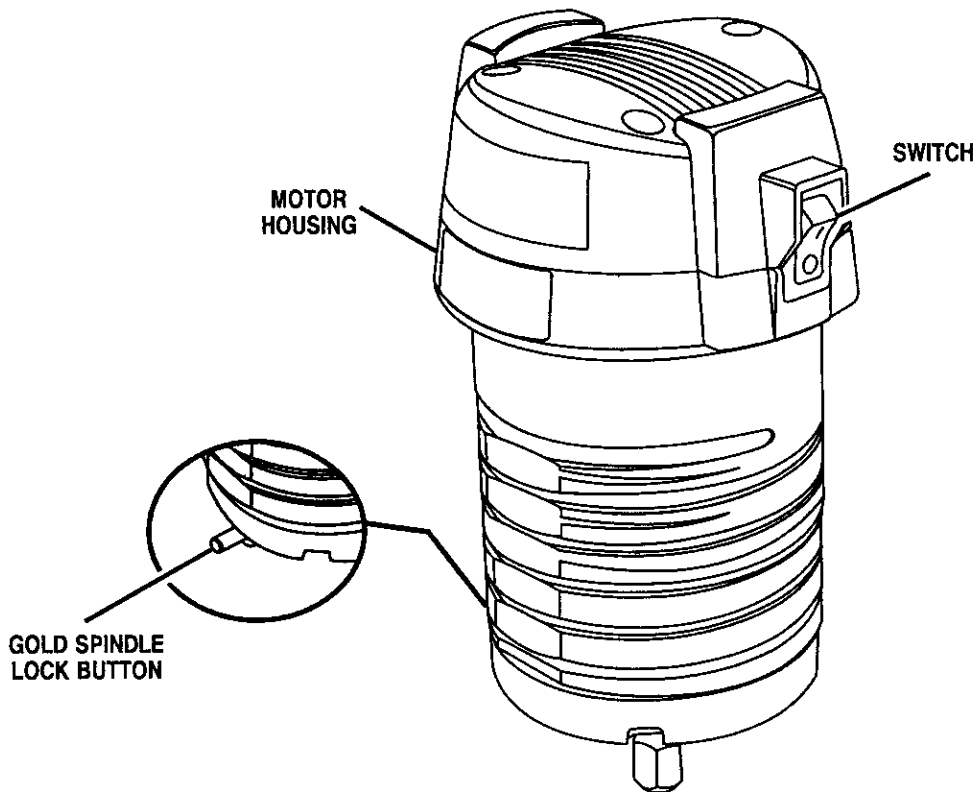

Fig. 1

UNPACKING

INSTRUCTIONS

- Carefully remove the tool and the accessories from the box.
- Make sure that all items listed in the packing list are included.
- Inspect the tool carefully to be sure no breakage or damage occurred during shipping.
- Do not discard the packing material until you have carefully inspected and satisfactorily operated the tool.
- If any parts are damaged or missing, please call 1-800-932-3188 for assistance.

PACKING LIST

Router Motor
Wrench
Operator's Manual

 **WARNING:** If any parts are missing, do not operate your tool until the missing parts are replaced. Failure to do so could result in serious personal injury.

 **WARNING:** The router should never be connected to a power supply when you are assembling parts, making adjustments, cleaning, performing maintenance, or when the tool is not in use. Disconnecting the tool prevents accidental starting that could cause serious injury.

OPERATION

⚠ WARNING: Never connect the router to power supply when you are assembling parts, making adjustments, installing or removing cutters, or when not in use. Disconnecting the router prevents accidental starting that could cause serious injury.

REMOVING AND INSTALLING THE ROUTER BASE

TO SWITCH FROM THE FIXED BASE OR D-HANDLE BASE TO THE PLUNGE BASE

See Figures 2 and 3.

TO REMOVE THE FIXED OR D-HANDLE BASE:

1. Unplug the router.

⚠ WARNING: Failure to unplug the tool could result in accidental starting causing serious.

2. Place the router upside down with the Craftsman label away from you.
3. Loosen the locking arm on the base.
4. Depress and hold the gold spindle lock button. The gold spindle lock button will not depress fully unless it is in line with the hole in the collet.
5. If the gold spindle lock button does not depress fully, turn the collet nut while depressing the gold spindle lock button. As they align, the gold spindle lock button will depress fully.

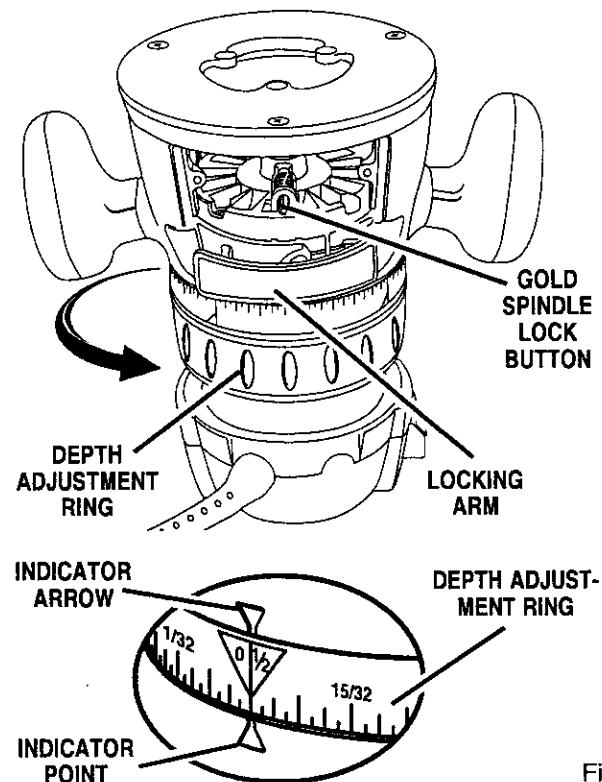

Fig. 2

6. Turn the depth adjusting ring counterclockwise until the motor is to its highest position. **NOTE:** As the motor is rising, the gold spindle lock button has to be depressed until it clears the rear window.
7. Align the indicator arrow on the depth adjustment ring with the indicator point on the base.
8. Pull the base until it dislodges from the motor housing.

TO INSTALL THE PLUNGE BASE

1. Unplug the router.
2. Place the plunge base on a flat surface.
3. Loosen the locking knob.
4. Align the groove in the motor housing with the rib inside the base. **NOTE:** The rib is located on the inside of the base in line with the handle.
5. Depress and hold the gold spindle lock button.
6. Slide the motor housing into the base.
7. Tighten the locking knob.

⚠ CAUTION: Do not tighten the locking knob without the motor installed in the base. Failure to heed this caution may result in permanent damage to the locking mechanism.

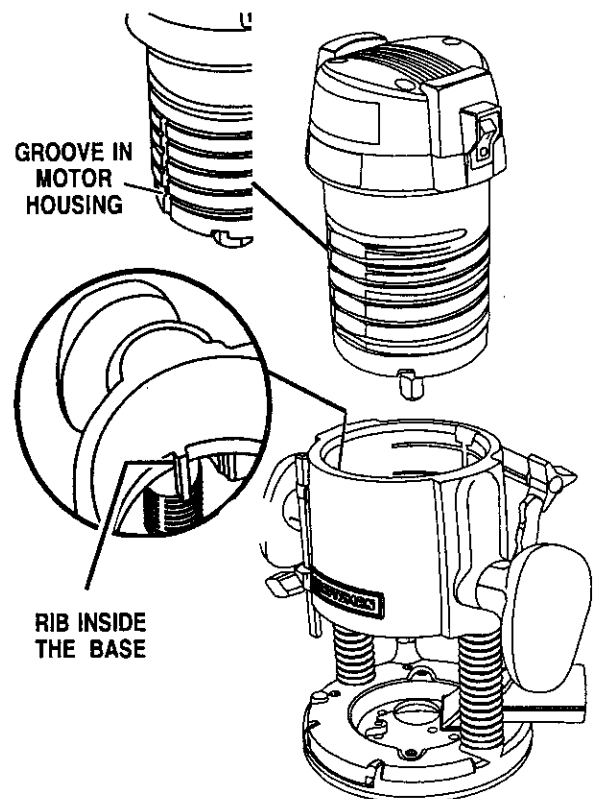

Fig. 3

OPERATION

TO SWITCH FROM PLUNGE BASE TO FIXED BASE OR D-HANDLE BASE

See Figures 4, 5, and 6.

TO REMOVE THE PLUNGE BASE

1. Unplug the router.

⚠ WARNING: Failure to unplug the tool could result in accidental starting causing serious injury.

2. Place the router on a flat surface.
3. Loosen the locking knob.
4. Depress and hold the gold spindle lock button. The gold spindle lock button will not depress fully unless it is in line with the hole in the collet.
5. If the gold spindle lock button does not depress fully, turn the collet nut while depressing the gold spindle lock button. As they align, the gold spindle lock button will depress fully.
6. Remove the motor housing from the plunge base.
NOTE: As the motor is being removed from the base, the gold spindle lock button has to be depressed until it clears the opening beneath the base.

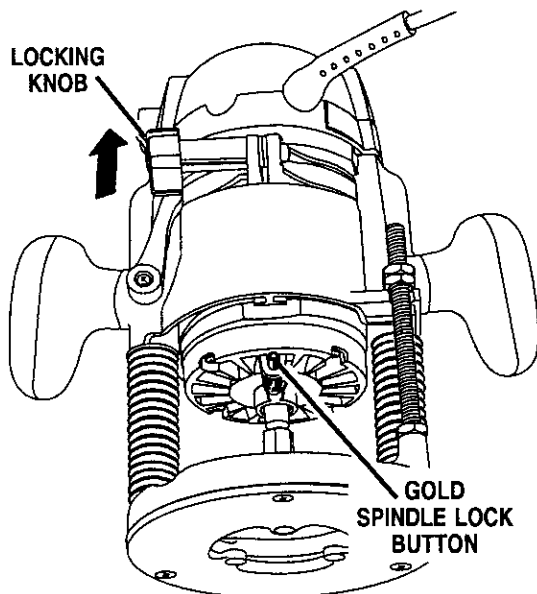

Fig. 4

TO INSTALL THE FIXED OR D-HANDLE BASE

1. Unplug the router.
2. Place the fixed or D-handle base on a flat surface.
3. Loosen the locking arm.
4. Align the indicator arrow on the depth adjustment ring with the indicator point on the base.
5. Align the groove in the motor housing with the tab inside of the base. **NOTE:** The tab is located on the inside of the base in line with the handle.
6. Depress and hold the gold spindle lock button on the motor.
7. Slide the motor housing into the base.
8. Turn the depth adjusting ring counterclockwise until the gold spindle lock snaps out as it clears the rear window, just below the locking arm.
9. Tighten the locking arm.

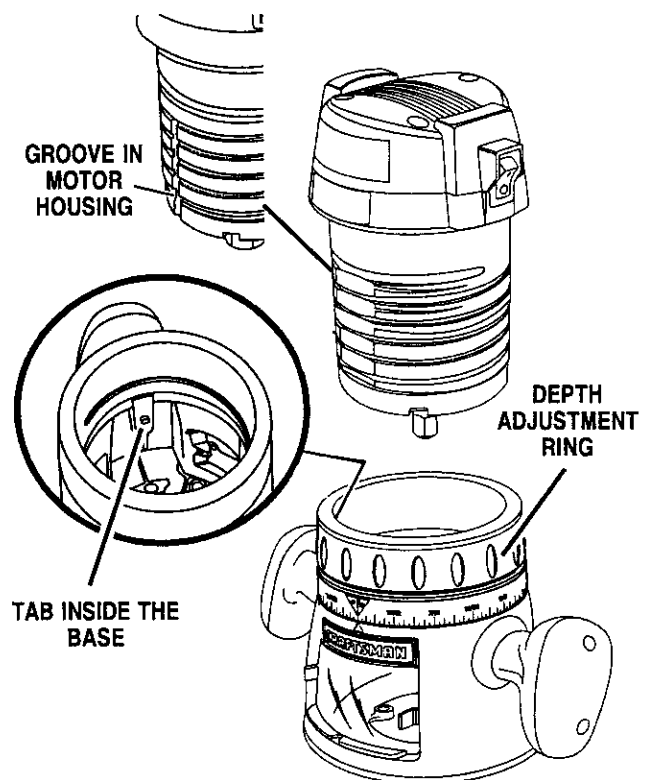

Fig. 5

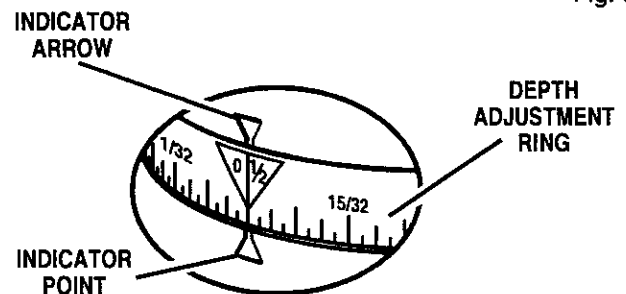

Fig. 6

OPERATION

REMOVING/INSERTING CUTTERS

See Figure 7.

Follow these steps to remove or insert cutters.

1. Unplug the router.

⚠ WARNING: Failure to unplug the tool could result in serious injury due to accidental starting.

⚠ CAUTION: To prevent damage to the spindle or spindle lock, always allow motor to come to a complete stop before engaging the spindle lock.

2. Lay the router down on a workbench in order to gain easy access to collet nut.
3. Depress and hold the spindle lock button.
4. Loosen the collet nut by turning it counterclockwise with the wrench provided.

⚠ WARNING: If you are changing a cutter immediately after use, be careful not to touch the cutter or collet with your hands or fingers. Always use the wrench provided.

5. Choose one of these options:

■ *To remove the cutter:* Remove the cutter from the collet.

■ *To insert the cutter:*

- a) Insert the shank of the cutter until the shank bottoms out, then pull it out 1/16 in. (1.6 mm) to allow for expansion when the bit gets hot.
- b) Tighten the collet nut securely by turning it clockwise with the wrench provided.
- c) Release the spindle lock button.

⚠ WARNING: If the collet nut is not securely tightened, the cutter may detach during use causing serious personal injury.

⚠ WARNING: Do not use cutters with undersized shanks. Undersized shanks will not tighten properly and could be thrown from the tool causing injury.

⚠ WARNING: Do not use cutters that are larger in diameter than the opening in router base. Use of such cutters will come in contact with the router base and damage both the cutter and router base. This situation could also cause possible loss of control or create other hazardous conditions that could cause possible serious personal injury.

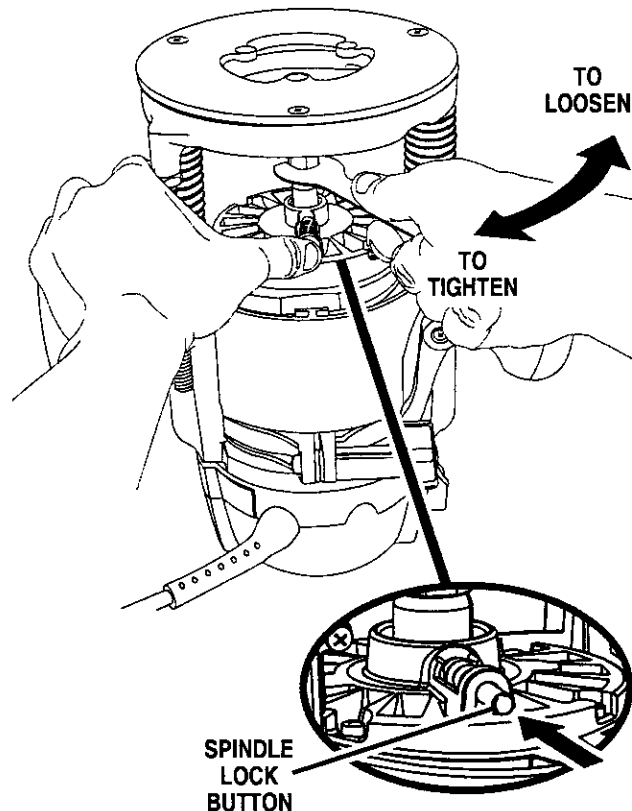

Fig. 7

ADJUSTING DEPTH OF CUT

Proper depth of cut depends on several factors: the horsepower of the router motor, the type of cutter, and the type of wood. A lightweight, low horsepower router is designed for making shallow cuts. A router with a high horsepower rating can safely cut deeper. Small cutters, such as veining bits with 1/16 in. (1.6 mm) cutting diameters, are designed to remove only small amounts of wood. Large cutters, such as straight-flute bits, are made to remove larger amounts of wood. You can make deeper cuts in soft woods, such as white pine, than in hardwoods, like oak or maple.

Based on these considerations, choose a depth of cut that will not place excessive strain on the router motor. If you find that extra force is needed or that the motor speed slows down considerably, turn off the router and reduce the depth of cut. Then, make the cut in two or more passes.

When routing a groove that is too deep to safely cut in one pass, it is best to make the cut in several passes. We recommend that cuts be made at a depth not exceeding 1/8 in. (3.2 mm) and that several passes be made to reach deeper cuts.

Adjusting the depth of cut for the plunge router is different from adjusting the depth of cut for the fixed router.

OPERATION

TO ADJUST DEPTH OF CUT FOR PLUNGE BASE ROUTERS

See Figures 8, 9, 10 and 11.

Follow these steps to adjust depth of cut for plunge base routers.

1. Unplug the router.

⚠ WARNING: Failure to unplug the tool could result in serious injury due to accidental starting.

2. Place the router on a flat surface.
3. Loosen the stop bar knob.
4. Unlock the plunge lock lever.
5. Plunge the router until the tip of the cutter touches

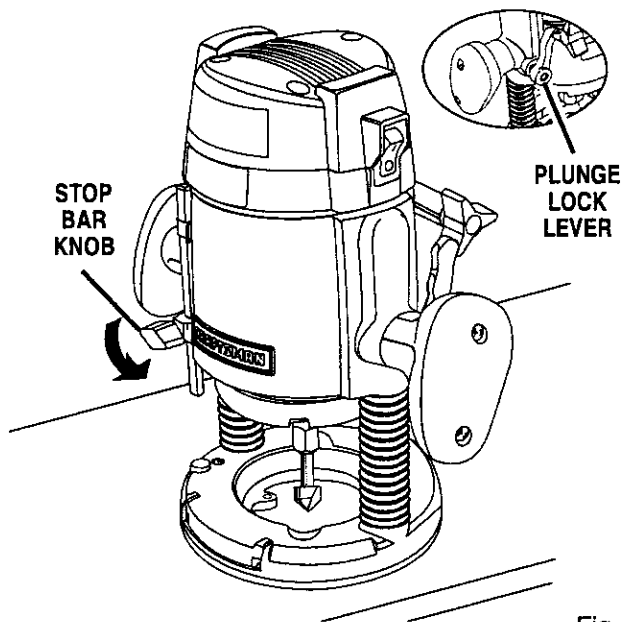

Fig. 8

the flat surface.

6. Lock the plunge lock lever.
7. Move the stop bar down so that it touches the depth stop.
8. Tighten the stop bar knob securely.
9. Set the depth indicator to zero.
10. Loosen the stop bar knob.
11. Set the depth indicator to the desired depth of cut.
Note: Each mark on the scale indicates 1/16 in. (1.6 mm).
12. Tighten the stop bar knob securely.
13. Unlock the plunge lock lever.
14. Position the router so that the cutter can extend below the subbase for desired depth of cut.

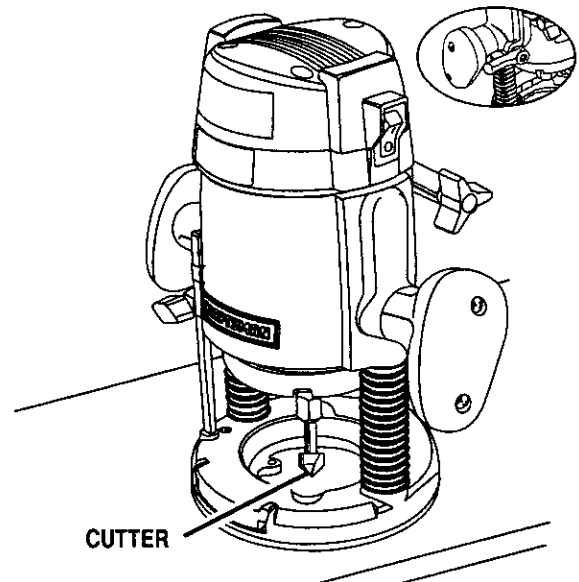

Fig. 9

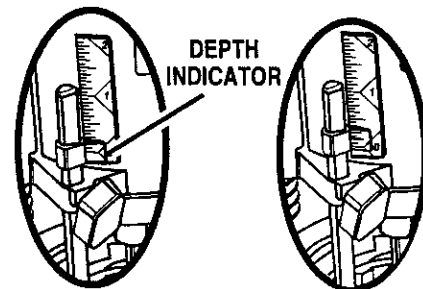

Fig. 10

15. Plunge the router until the stop bar touches the depth stop.
16. Lock the plunge lock lever to position the cutter at the desired depth of cut.

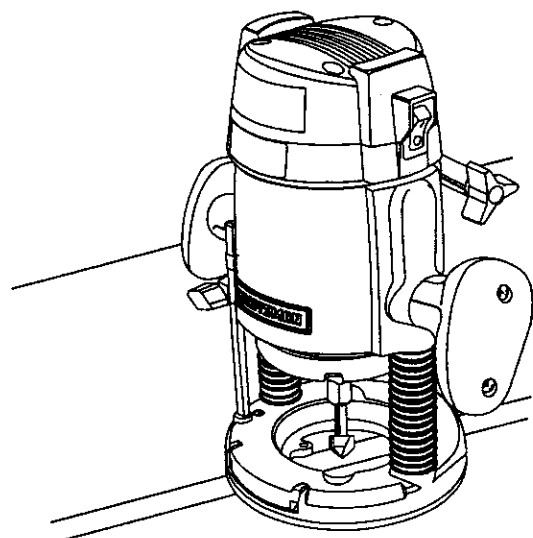

Fig. 11

OPERATION

TO ADJUST DEPTH OF CUT FOR FIXED BASE ROUTERS

See Figures 12, 13, and 14.

Follow these steps to adjust depth of cut for fixed base routers.

1. Unplug the router.

⚠ WARNING: Failure to unplug the tool could result in serious injury due to accidental starting.

2. Place the router on a flat surface.
3. Loosen the locking arm.
4. Turn the depth adjustment ring counterclockwise until the tip of the cutter touches the flat surface.
5. Turn the depth indicator ring until the zero lines up

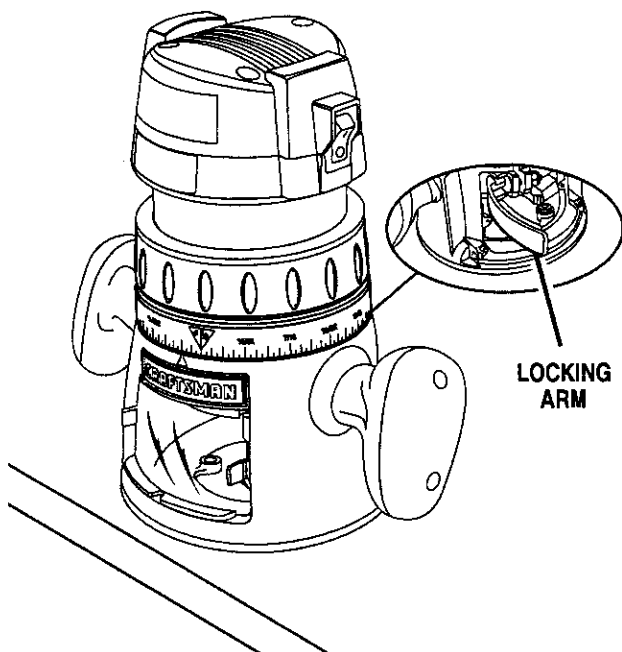

Fig. 12

with the indicator point on the base.

6. Position the router so that the cutter can extend below the subbase for desired depth of cut.
7. Turn the depth adjustment ring to obtain the desired depth of cut.

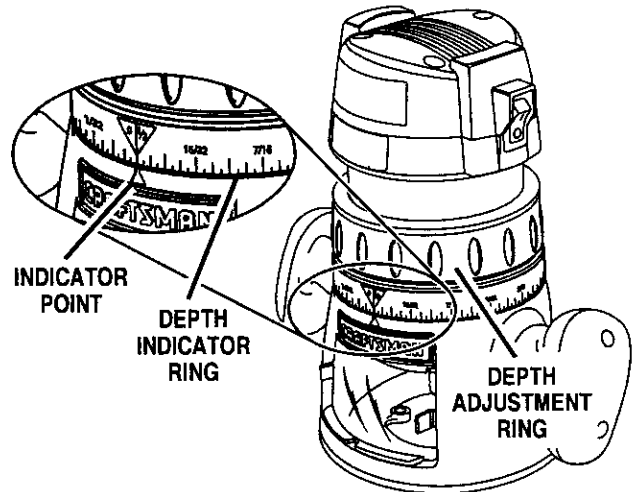

Fig. 13

8. Tighten the locking arm securely.

Note: To adjust the depth of cut when the router is mounted to a router table, turn the depth adjustment ring until the cutter reaches the desired depth of cut.

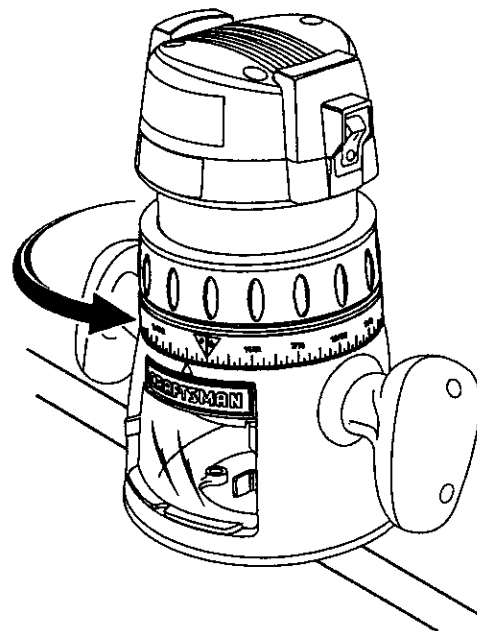

Fig. 14

OPERATION

⚠ WARNING: Always wear safety goggles or safety glasses with side shields when operating this tool. Failure to do so could result in dust, shavings, chips, or loose particles being thrown in your eyes resulting in possible serious injury. If the operation is dusty, also wear a face or dust mask.

⚠ WARNING: Never attempt to use the router motor without first installing it in one of the approved bases. Failure to heed this warning could result in personal injury and damage to the motor.

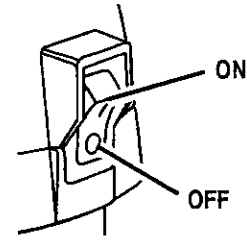

Fig. 15

TURNING ON/OFF THE ROUTER

See Figure 15.

- To turn on the router: Toggle the switch to the I position.
- To turn off the router: Toggle the switch to the O position.

OPERATING THE ROUTER

See Figures 16 and 17.

Follow these steps to operate the router.

1. Unplug the router.

⚠ WARNING: Failure to unplug the tool could result in serious injury due to accidental starting.

2. Tighten securely the cutter in the collet nut. Refer to REMOVING/INSERTING CUTTERS earlier in this manual.
3. Set the desired depth of cut. Refer to ADJUSTING DEPTH OF CUT earlier in this manual.
4. Secure the workpiece.
5. Plug the router into a power source.
6. Hold the router firmly with both hands.
7. Turn on the router and let the motor build to its full speed.
8. Feed the cutter slowly into the workpiece.

Note: Do not let the cutter contact the workpiece before starting the router and allowing it to develop full speed.

9. Turn off the router upon completion of cut, and let the motor come to a complete stop before removing the router from the workpiece.

⚠ WARNING: Never place the router down on a work surface before the cutter stops.

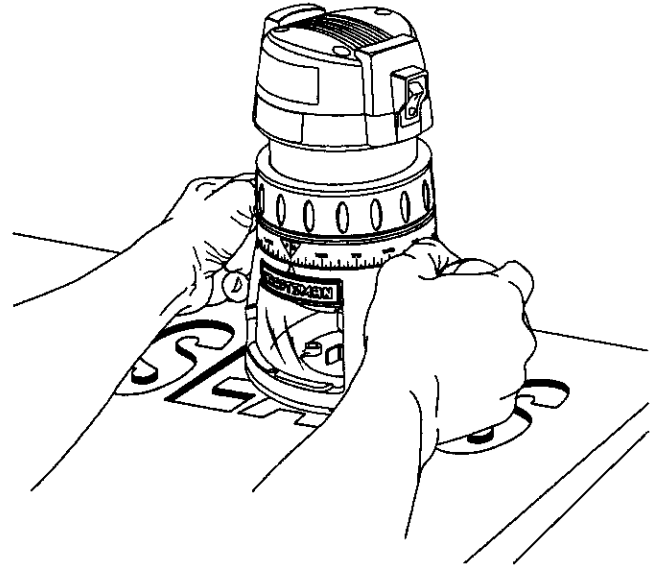

Fig. 16

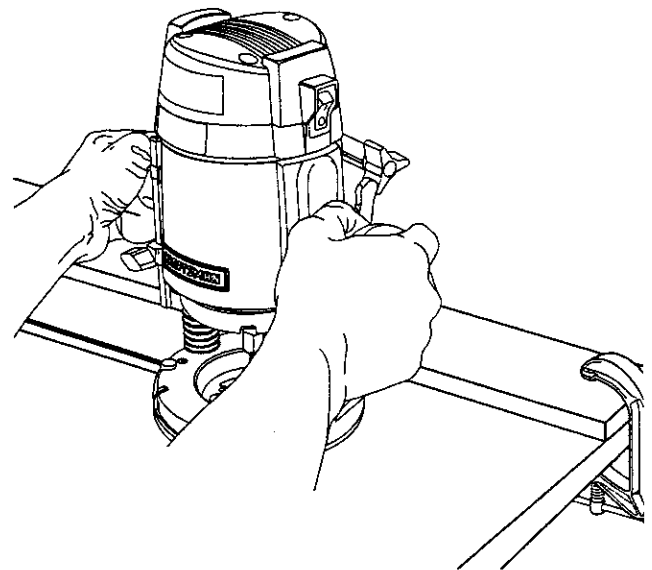

Fig. 17

OPERATION

FEEDING THE ROUTER

The "secret" of professional routing lies in making a careful set-up for the cut and in selecting the proper rate of feed.

DIRECTION (EXTERNAL)

See Figure 18.

When routing, the cutter rotates clockwise. Therefore, you should feed the router into the workpiece from left to right. When you feed the router from left to right, the rotation of the cutter pulls the router against the workpiece. If you feed the router in the opposite direction, the rotational forces of the spinning bit tend to throw the router away from the workpiece. This action could cause you to lose control of the router.

The router motor and bit revolve in a clockwise direction. This gives the tool a slight tendency to twist in a counterclockwise direction, especially when the motor revs up.

Because of the extremely high speed of bit rotation during a proper feeding operation, there is very little kickback under normal conditions. However, if the bit strikes a knot, hard grain, or foreign object that affects the normal progress of the cutting action, there will be a slight kickback. This kickback is sufficient to spoil the trueness of your cut if you are not prepared. Such a kickback is always in the direction opposite the direction of bit rotation.

To guard against such a kickback, plan your setup and direction of feed so that you will always be thrusting the tool—to hold it against whatever you are using to guide the cut—in the same direction that the leading edge of the bit is moving. In short, the thrust should be in a direction that keeps the sharp edges of the bit continuously biting straight into new (uncut) wood.

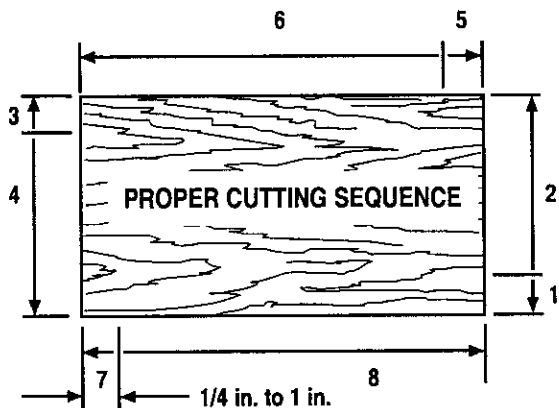

Fig. 18

DIRECTION (INTERNAL)

See Figure 19.

Whenever you are routing a groove, your travel should be in a direction that places whatever guide you are using at the right-hand side. That is, when the guide is positioned as shown in the first part of the figure, tool travel should be from left to right and counterclockwise around curves. When the guide is positioned as shown in the second part of the figure, tool travel should be from right to left and clockwise around curves. If there is a choice, the first setup is generally the easier to use. In either case, the sideways thrust you use is against the guide.

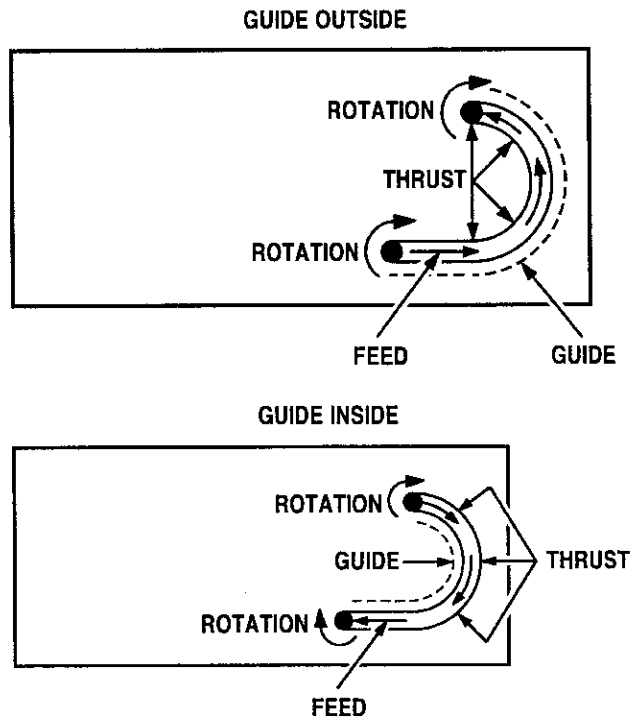

Fig. 19

OPERATION

RATE OF FEED

The proper rate of feed depends on several factors: the hardness and moisture content of the wood, the depth of cut, and the cutting diameter of the bit. When cutting shallow grooves in soft woods such as pine, you may use a faster rate of feed. When making deep cuts in hardwoods such as oak, you should use a slower rate of feed.

The best rate of feed is one that does not slow down the router motor more than one-third of its no load speed. If you feed the router too fast, it will take large chips out of the wood and leave gouge marks. If you feed the router too slowly, it will scorch or burn the wood.

Feeding Too Fast *See Figure 20.*

Clean, smooth routing and edge shaping can be done only when the bit is revolving at a relatively high speed and is taking very small bites to produce tiny, cleanly severed chips. If you force the router to move forward too fast, the RPM of the bit becomes slower than normal in relation to its forward movement. As a result, the bit must take bigger bites as it revolves. Bigger bites mean bigger chips and a rougher finish. Also, because bigger bites require more power, the router motor may become overloaded.

Under extreme force-feeding conditions, the relative RPM of the bit can become so slow—and the bites it has to take so large—that chips will be partially knocked off (rather than fully cut off). This causes splintering and gouging of the workpiece.

The router is an extremely high-speed tool, and will make clean, smooth cuts if allowed to run freely without the overload of a forced feed. You can always detect force feeding by the sound of the motor. Its high-pitched whine will sound lower and stronger as it loses speed. Also, the strain of holding the tool will be noticeably increased.

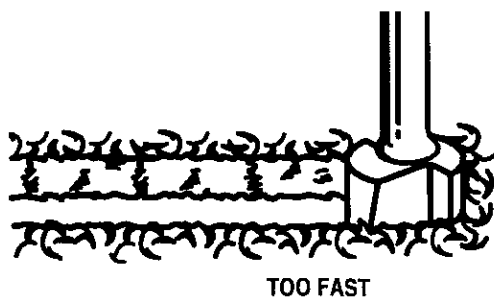

TOO FAST

Fig. 20

Feeding Too Slow *See Figure 21.*

It is also possible to spoil a cut by moving the router forward too slowly. When you advance the router into the work too slowly, the revolving bit does not dig into new wood fast enough to take a bite; instead, it merely scrapes away sawdust-like particles. Scraping produces heat, which can glaze, burn, or mar the cut and in extreme cases, can even overheat the bit, destroying its hardness.

In addition, when the bit is scraping instead of cutting, it is more difficult to control the router. With practically no load on the motor, the bit revolves at close to top RPM, and has a much greater than normal tendency to bounce off the sides of the cut (especially if the wood has a pronounced grain with hard and soft areas). As a result, the cut produced may have rippled, instead of straight, sides.

Feeding too slow can also cause the router to take off in a wrong direction from the intended line of cut. Always grasp and hold the router firmly with both hands when routing.

You can detect when you are feeding the router too slowly by the runaway, high-pitched sound of the motor or by feeling the wiggle of the bit in the cut.

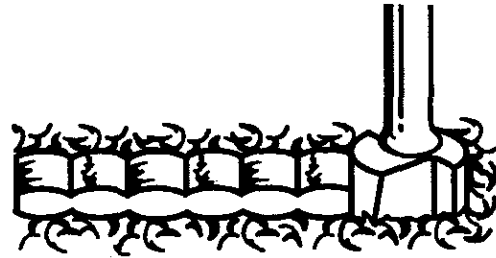

TOO SLOW

Fig. 21

OPERATION

DEPTH OF CUT

See Figure 22.

As previously mentioned, the depth of cut is important because it affects the rate of feed that, in turn, affects the quality of the cut (and, also, the possibility of damage to the router motor and bit). A deep cut requires a slower feed than a shallow one. A cut that is too deep causes you to slow the feed so much that the bit no longer cuts; instead it scrapes.

Making a deep cut is never advisable. The smaller bits—especially those only 1/16 inch (1.6 mm) in diameter—are easily broken off when subjected to too much side thrust. A large enough bit may not be broken, but if the cut is too deep a rough cut will result—and it may be very difficult to guide and control the bit as desired. For these reasons, we recommend that you do not exceed 1/8 in. depth of cut in a single pass, regardless of the bit size or the softness or condition of the workpiece.

Therefore, to make deeper cuts, make many successive passes, lowering the bit 1/8 in. for each new pass. In order to save time, do all the cutting necessary at one depth setting before lowering the bit for the next pass. This also assures a uniform depth when you complete the final pass.

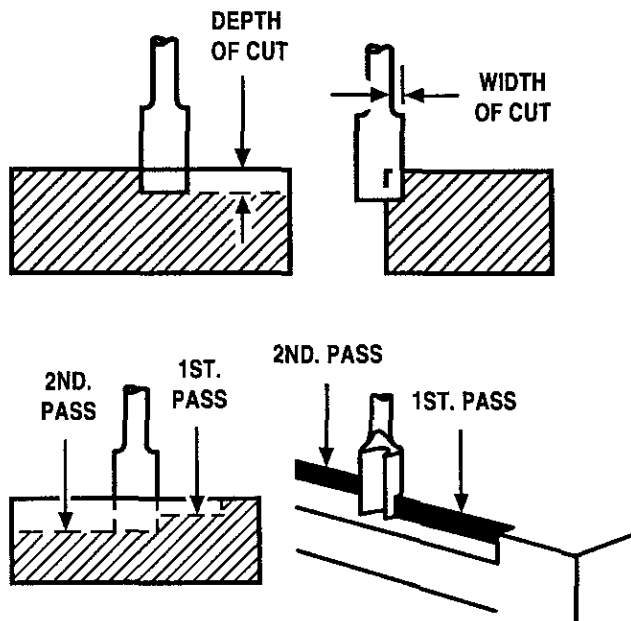

Fig. 22

MAINTENANCE

⚠ WARNING: When servicing, use only identical Craftsman replacement parts. Use of any other part may create a hazard or cause product damage.

GENERAL

Only the parts shown on the parts list, are intended to be repaired or replaced by the customer. All other parts represent an important part of the double insulation system and should be serviced only by a qualified Sears service technician.

Avoid using solvents when cleaning plastic parts. Most plastics are susceptible to damage from various types of commercial solvents and may be damaged by their use. Use clean cloths to remove dirt, carbon dust, etc.

⚠ WARNING: Do not at any time let brake fluids, gasoline, petroleum-based products, penetrating oils, etc. come in contact with plastic parts. They contain chemicals that can damage, weaken or destroy plastic.

Electric tools used on fiberglass material, wallboard, spackling compounds, or plaster are subject to accelerated wear and possible premature failure because the fiberglass chips and grindings are highly abrasive to bearings, brushes, commutators, etc. Consequently, we do not recommend using this tool for extended work on these types of materials. However, if you do work with any of these materials, it is extremely important to clean the tool using compressed air.

⚠ WARNING: Always wear safety goggles or safety glasses with side shields during power tool operation or when blowing dust. If an operation is dusty, also wear a dust mask. Failure to do so could result in possible serious injury.

CUTTERS

Get faster more accurate cutting results by keeping cutters clean and sharp. Remove all accumulated pitch and gum from cutters after each use.

When sharpening cutters, sharpen only the inside of the cutting edge. Never grind the outside diameter. Be sure when sharpening the end of a cutter to grind the clearance angle the same as originally ground.

COLLET

From time to time, it also becomes necessary to clean your collet and collet nut. To do so, simply remove collet nut from collet and clean the dust and chips that have collected. Then return collet nut to its original position.

ADJUSTING LOCKING ARM TENSION

Over time and with repeated use, the locking arm may become loose. When this occurs, tighten the elastic stop nut slightly. The elastic stop nut should be loose enough so there is some play in the locking arm when it is in the open position. Make sure the motor housing does not move up or down when clamped.

NOTE: Do not over tighten the elastic stop nut. The locking arm should clamp tightly to secure the motor housing.

If the locking arm becomes worn beyond adjustment, a repair kit is available. Please contact your service center to order the appropriate router locking arm repair kit.

LUBRICATION

All of the bearings in this tool are lubricated with a sufficient amount of high grade lubricant for the life of the unit under normal operating conditions. Therefore, no further lubrication is required.

ACCESSORIES

THE FOLLOWING RECOMMENDED ACCESSORIES ARE CURRENTLY AVAILABLE AT SEARS RETAIL STORES.

Dovetail Template











Butt Hinge Template

Multi-Purpose Router Guide

Rout-A-Form Pantograph

Template Set

Template Guide Bushing

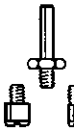
COMBI-NATION PANEL CUTTER	VEINING BIT	CORE BOX BIT V-GROOVE CHAMFER	STRAIGHT FACE BIT	COMBI-NATION STRAIGHT, BEVEL CUTTER	HINGE MORTISING BIT	DOVETAIL CUTTER BITS	RABBET BIT	OGEE, ROMAN O	COVE BIT, 45° CHAMFER BIT	BEAD QUARTER-ROUND BIT	ARBOR WITH BALL BEARINGS 2589 WITH 2 BALL BEARINGS (1/2 in. & 5/8 in.) *25895
											
* FOR CARBIDE TIPPED EDGE FORMING BITS											

* 25895 FOR CARBIDE TIPPED EDGE FORMING BITS
2589 FOR HIGH SPEED STEEL EDGE FORMING BITS

WARNING: The use of attachments or accessories not listed above might be hazardous.

ROUTER TABLES

With a router table your router is converted into a high-speed shaper.

WARNING: Only use router tables with proper guarding for the cutter and with "on board" switch controlled receptacles (Part No. 9-25188). Failure to use router tables with appropriate safety features could result in serious personal injury.

CRAFTSMAN ROUTER MOTOR - MODEL NUMBER 315.175341

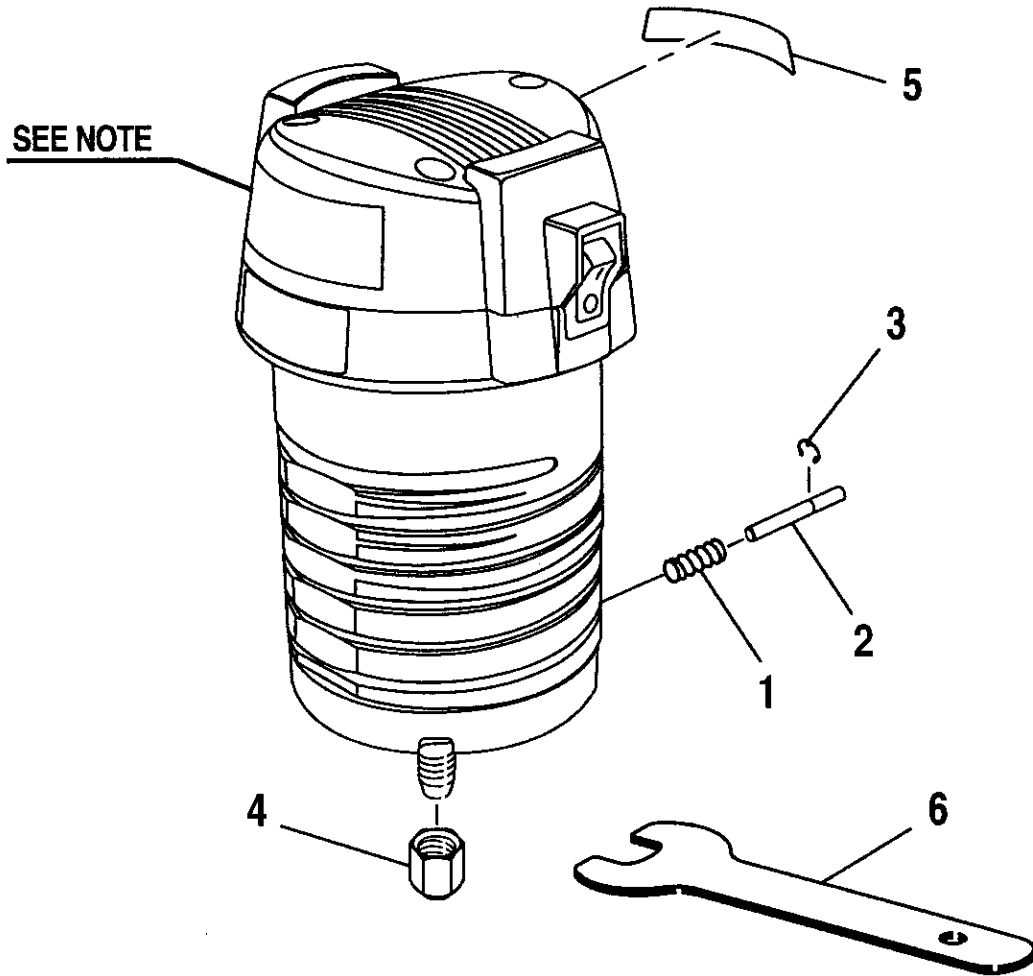

Note: The assembly shown represents an important part of the double insulated system. To avoid the possibility of alteration or damage to the system, service should be performed by your nearest Sears repair center. Contact your nearest Sears retail store for service center information.

CRAFTSMAN ROUTER MOTOR – MODEL NUMBER 315.175341

The model number will be found on a plate attached to the motor housing. Always mention the model number in all correspondence regarding your **ROUTER MOTOR** or when ordering repair parts.

SEE BACK PAGE FOR PARTS ORDERING INSTRUCTIONS

PARTS LIST

Key No.	Part No.	Description	Qty.
1	690141001	Shaft Lock Spring	1
2	671457001	Shaft Lock Pin	1
3	671245001	* E-Ring **STD581018	1
4	690190001	Collet Nut	1
5	940301011	Data Plate	1
6	671250001	Wrench	1
	983000-435	Operator's Manual	1

* Standard Hardware Item – May Be Purchased Locally
** Available from Div. 98 – Source 980.00

Get it fixed, at your home or ours!

Your Home

For repair – **in your home** – of **all** major brand appliances, lawn and garden equipment, or heating and cooling systems, **no matter who made it, no matter who sold it!**

For the replacement parts, accessories and owner's manuals that you need to do-it-yourself.

For Sears professional installation of home appliances and items like garage door openers and water heaters.

1-800-4-MY-HOME® (1-800-469-4663)

Call anytime, day or night (U.S.A. and Canada)

www.sears.com www.sears.ca

Our Home

For repair of carry-in items like vacuums, lawn equipment, and electronics, call or go on-line for the location of your nearest **Sears Parts & Repair Center.**

1-800-488-1222

Call anytime, day or night (U.S.A. only)

www.sears.com

To purchase a protection agreement (U.S.A.) or maintenance agreement (Canada) on a product serviced by Sears:

1-800-827-6655 (U.S.A.)

1-800-361-6665 (Canada)

Para pedir servicio de reparación a domicilio, y para ordenar piezas:

1-888-SU-HOGARSM

(1-888-784-6427)

Au Canada pour service en français:

1-800-LE-FOYER^{MC}

(1-800-533-6937)

www.sears.ca

SEARS